

STA-RITE® PRO-Storm™ DSS Series

Multi-stage



The Pro-Storm™ multi-stage series of sprinker pumps delivers high-performance without priming problems and delays.

The Pro-Storm multi-stage series is designed for minimal electrical consumption and quiet operation from the professional-grade motor. The new Pro-Storm multi-stage series offers first-in-class priming capabilities of up to 15 foot lifts!

APPLICATIONS

Booster
Chemical Distribution
Spot-Free Rinse
Self-Priming
Transfer

SPECIFICATIONS

Motor Bracket and Integral Pump Base:

Close-grained cast iron, 1-1/2" NPT inlet connection, stable heavy-duty design for rigid pipe and solid base mountings

Discharge: Close-grained cast iron, 1-1/4" NPT discharge connection, with easy-access drain port for end of season draining and winterization

Impellers and Diffusers: Noryl® precision-molded extra-smooth ports to maximize efficiency and performance

Outer Shell: Polished 304 stainless steel

Shaft: 303 stainless steel

Priming Valve: Special brass priming valve for trouble-free operation during the initial pump priming

Mechanical Seal: High-pressure seal, carbon-ceramic seal faces, Buna-N elastomers

Heavy-Duty Motor: 2 HP, single-phase, 3450 RPM, 230-volt, high-service factor, capacitor-start/capacitor-run, open drip-proof motor, rated for continuous-duty operation. 230/460 TEFC available

Maximum Inlet Pressure: 20 PSI

Maximum Discharge Pressure: 130 PSI

Maximum Operating Temperature: 120°F (49°C)

Maximum Suction Lift: 15 feet

Number of Stages: 3 or 4

ORDERING INFORMATION

Catalog Number	Stages	HP	Pipe Tapping Sizes		Motor Voltage	Approx. Wt. Lbs.
			Suction	Discharge		
DSS4HG	4	2	1-1/2" NPT	1-1/4" NPT	230 1ø	95
DSS4HG3T	4	2	1-1/2" NPT	1-1/4" NPT	230/460 TEFC	95
DSS3HG	3	2	1-1/2" NPT	1-1/4" NPT	230 1ø	95
DSS3HG3T	3	2	1-1/2" NPT	1-1/4" NPT	230/460 TEFC	95

Pentair trademarks and logos are owned by Pentair plc or its affiliates. All other third party registered and unregistered trademarks and logos are the property of their respective owners.

STA-RITE® PRO-Storm™ DSS Series

Multi-stage

PUMP PERFORMANCE

NOMINAL RPM: 3450, BASED ON FRESH WATER @ 68°F, MAXIMUM WORKING PRESSURE: 175 PSI

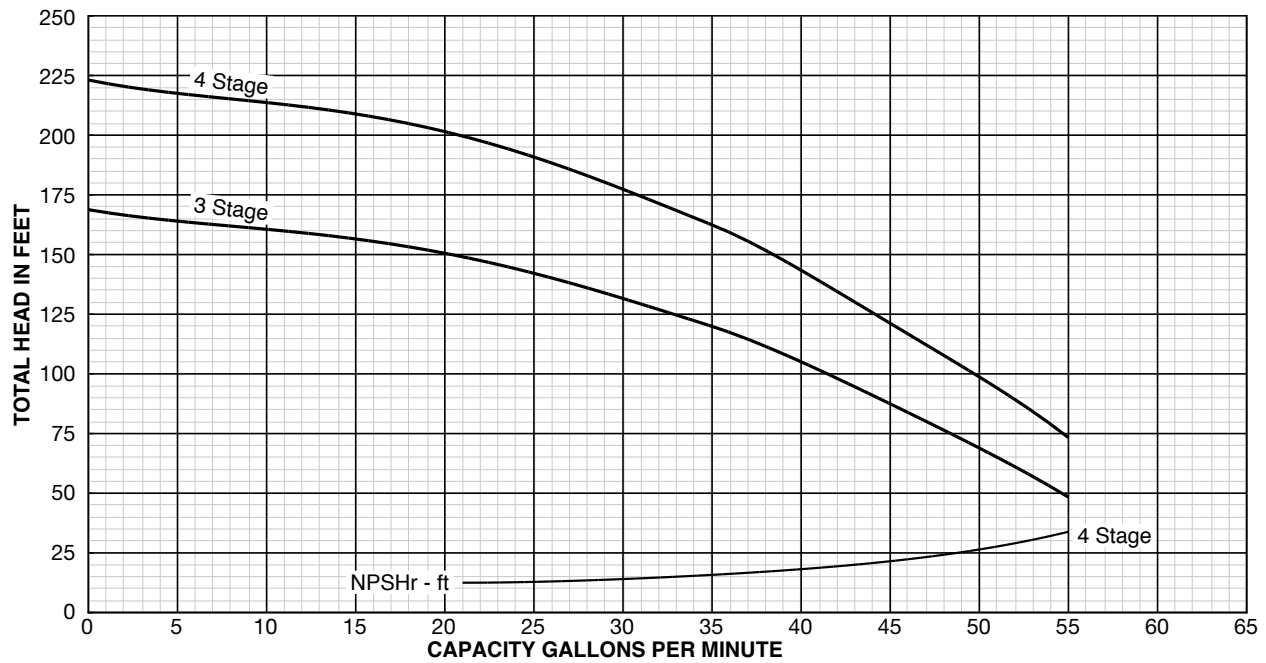

OUTLINE DIMENSIONS

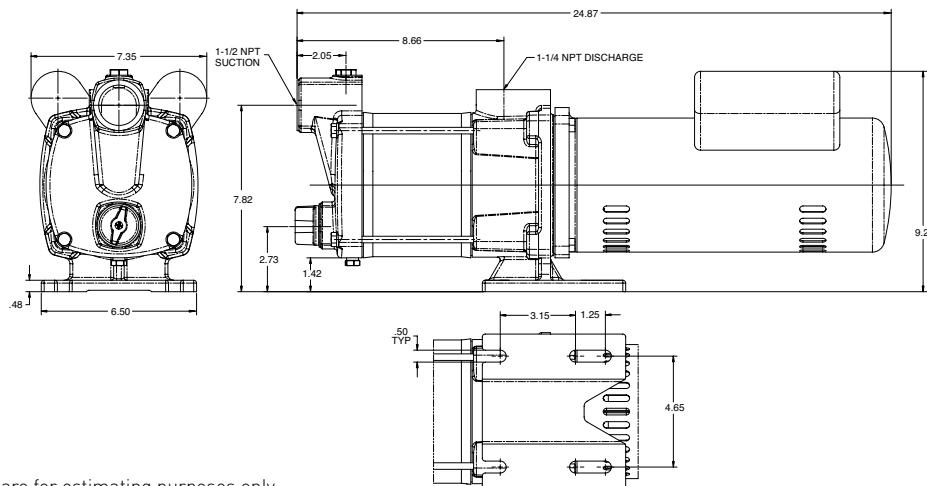

Dimensions (in inches) are for estimating purposes only.



US: 293 WRIGHT STREET, DELAVAN, WI 53115 WWW.STA-RITE.COM PH: 888-782-7483 ORDERS FAX: 800-426-9446
 CANADA: 490 PINEBUSH ROAD, UNIT 4, CAMBRIDGE, ONTARIO N1T 0A5 PH: 800-363-7867 ORDERS FAX: 888-606-5484
 Because we are continuously improving our products and services, Pentair reserves the right to change specifications without prior notice.